

Equipment & Service: Sealing Machine

Silgan White Cap 600-1

... with improved features!

The new sealing machine Silgan White Cap 600-1 consists of the basic machine 500-1 with the addition of the further developed features of its predecessor, type 600. This progress has been possible thanks to new concepts together with many years of experience.

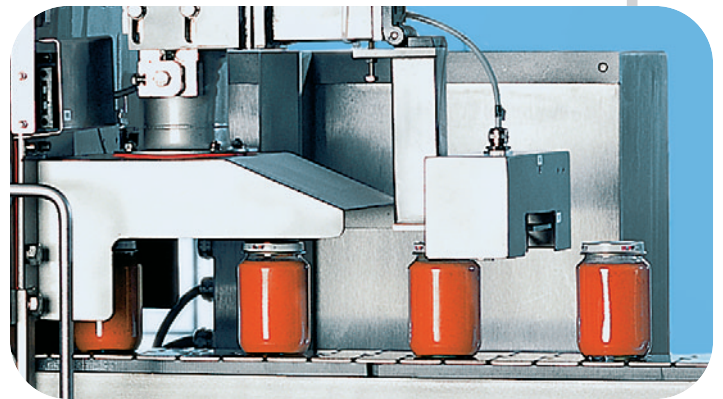

Improvements compared to the 600 series:

- Capping rates have been improved up to 1000 PT closures per minute.
- An additional two-point head clamp stabilises the machine head and avoids any possible vibrations during production.
- The new cam belt drive for the sealing and sidebelts reduces the noise level and at the same time results in less maintenance.
- A quick-release device for the set-up parts allows for simple set-up and adjustment for different Twist-Off® diameters and types.
- A separate lateral drag arm optimises the capping rate for Twist-Off® closures.
- Sliding doors within the front door guarantee faster, better access.



Technical Information

Sealing Machine Silgan White Cap 600-1

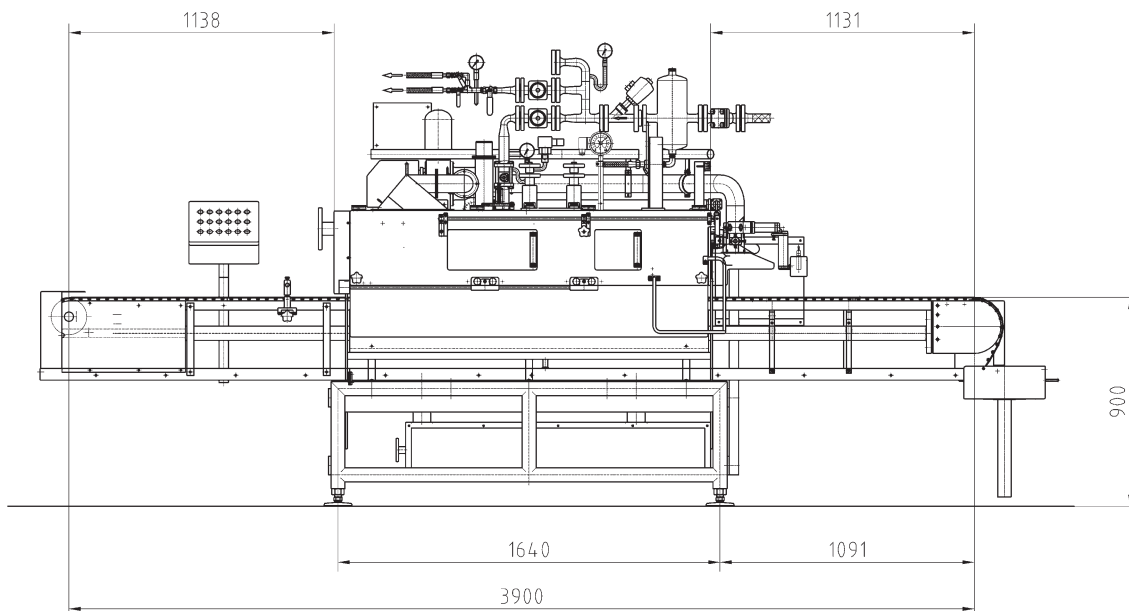

- **Electrical requirements** 400 V
50 Hz
7.5 kW
- **Steam requirements** 5 – 8 bar
50 – 120 kg/h
- **Steam supply line connection** DN 25
- **Exhaust pipe** Ø 150mm minimum
- **Preferably soft water** R 1/4", 0.25 m³/h
- **Max. line speed** 1.000 per min. for PT
850 per min. for Twist-Off®
depending on closure diameter and type
- **Closure types** Suitable for all Twist-Off® and PT closure types with
Ø 27mm – 110mm

