

Equipment & Service: Sealing Machine

Silgan White Cap 300

Silgan White Cap 300 has been developed for line speeds of up to 300 Twist-Off® closures per minute and short change-over times. It is designed primarily for companies working in the medium line speed range and processing products on several lines in parallel mode. It is available in right or left-handed configuration. The 300 replaces the previous sealing machine type Silgan White Cap 400.

It is based on the technical concept of the stainless steel sealing machine series Silgan White Cap 400, 500 and 600:

- Open frame of top quality stainless steel design for optimal cleaning and minimum maintenance
- Small front door and integrated sliding doors for easy access, rapid control, adjustment and cleaning
- Separate, synchronised drives for the machine head and conveyor with frequency converters for speed control, and line speed synchronisation via filling machine control voltage



- Machine head electronically adjustable to jar height

New Features:

- Split front door with opening of adequate size for regular production and with the added option of opening the whole door for easier access
- Simple set-up and adjustment and the new single-point attachment for the lower cap track, resulting in shorter change-over and maintenance times

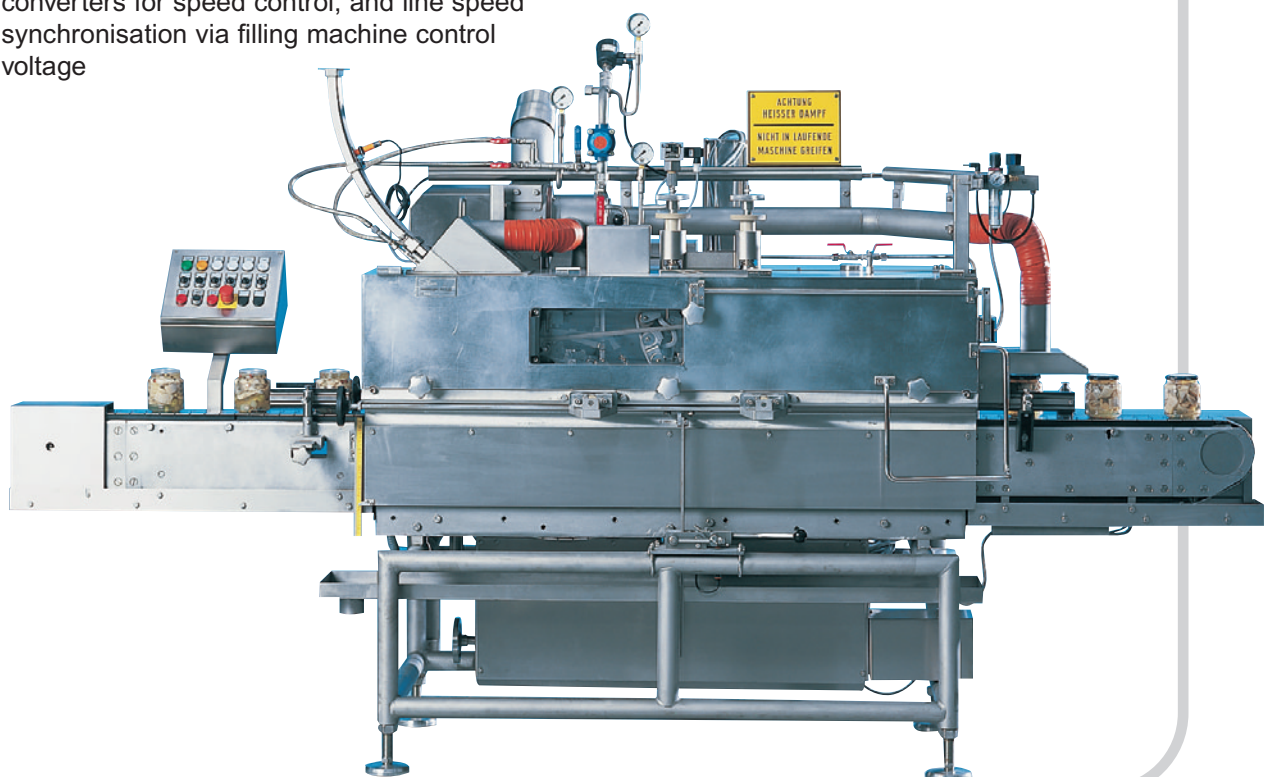

Technical Information

Sealing Machine Silgan White Cap 300

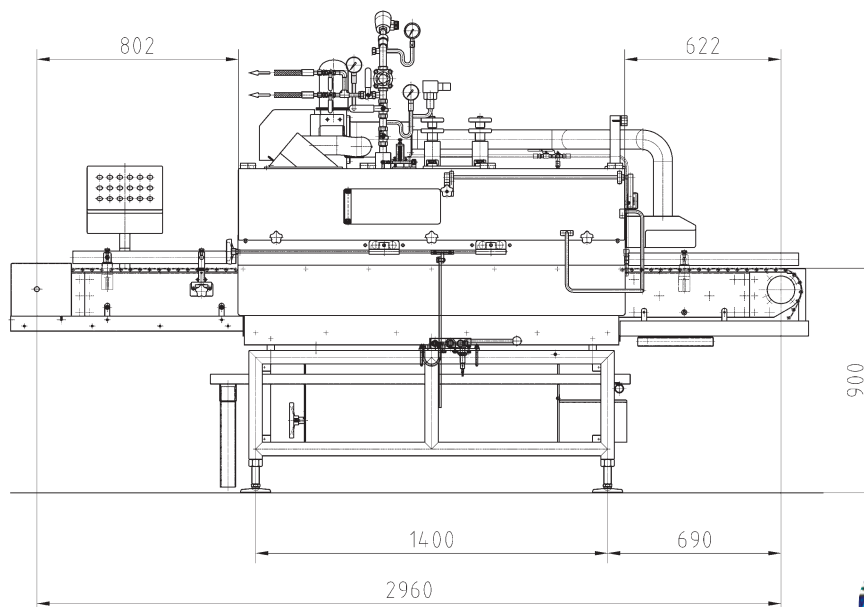

- **Electrical requirements** 400 V
50 Hz
3.5 kW
- **Steam requirements** 5 – 8 bar
30 – 90 kg/h
- **Steam supply line connection** R 3/4"
- **Exhaust pipe** Ø 150mm minimum
- **Preferably soft water** 0.25 m³/h
- **Max. line speed** 300 per min. for
Twist-Off® and PT
- **Closure types** Suitable for all Twist-Off® and
PT closure types with
Ø 27mm – 110mm

